

Audience Series: active extreme high output sound systems

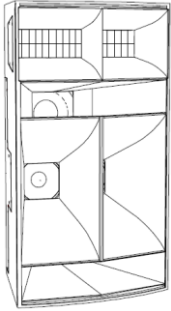

AH36

- Horizontal line array
- LM/M/H cabinet
- 2 x 12", Low/Mid
- 2 x 8", Mid
- 2 x RCD, High
- Air –system

[AH36 TechDoc](#)

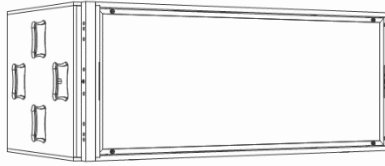

AV27

- Vertical line array
- L/M/H cabinet
- 1 x 15", Low
- 2 x 8", Mid
- 2 x RCD, High

[AV27 TechDoc](#)

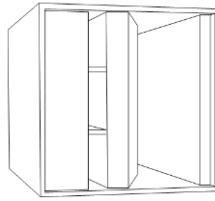

AB18

- Bass cabinet
- Bandpass / horn
- 1 x 18"

[AB18 TechDoc](#)

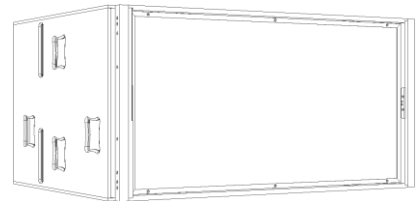

AB36 – AB37

- Bass cabinet
- Bandpass / horn
- 2 x 18"

[AB36 TechDoc](#)
[AB37 TechDoc](#)

Bass Series: bass and subbass cabinets

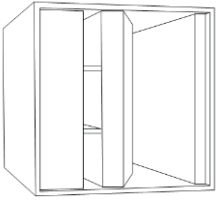

AB18

- Bass cabinet
- Bandpass / horn
- 1 x 18"

[AB18 TechDoc](#)

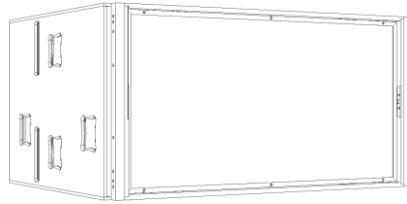

AB36 / AB37

- Bass cabinet
- Bandpass / horn
- 2 x 18"

[AB36 TechDoc](#)
[AB37 TechDoc](#)

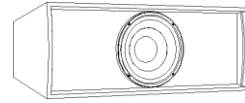

B12

- Bass cabinet
- Bass reflex
- 1 x 12"

[B12 TechDoc](#)

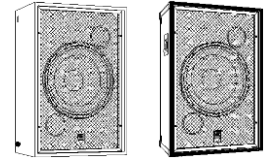

B15 / B15s

- Bass cabinet
- Bass reflex
- 1 x 15"

[B15 TechDoc](#)

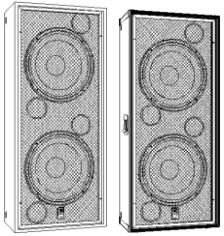

B30 / B30s

- Bass cabinet
- Bass reflex
- 2 x 15"

[B30 TechDoc](#)

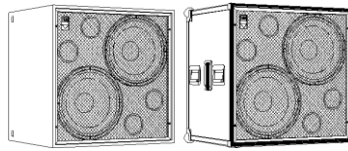

P16 / P16s

- Bass cabinet
- Bass reflex
- 2 x 15"

[P16 TechDoc](#)

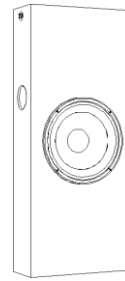

SL15

- Bass cabinet
- Bass reflex
- 1 x 15"

[SL15 TechDoc](#)

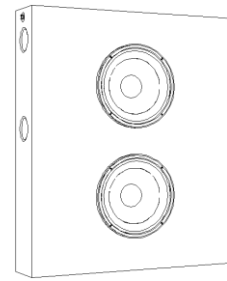

SL30

- Bass cabinet
- Bass reflex
- 2 x 15"

[SL30 TechDoc](#)



SSB18

- Bass cabinet
- Bandpass / horn
- 1 x 18"

[SSB18 TechDoc](#)



SSB36

- Bass cabinet
- Bandpass / horn
- 2 x 18"

[SSB36 TechDoc](#)

Blue Box

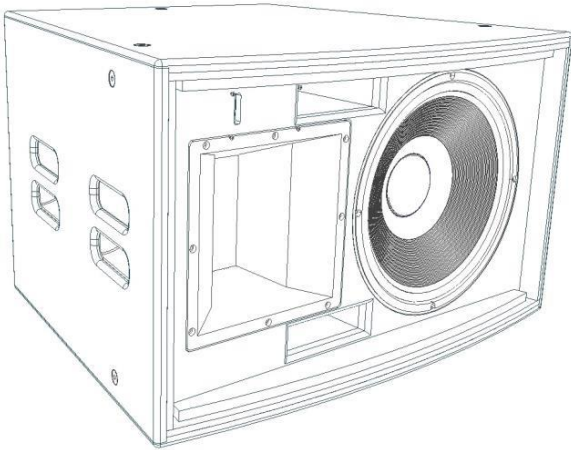

BB35

- 30Hz-32Hz (+/- 3dB)
- 120/132 dB program / peak

[BB35 techdoc](#)

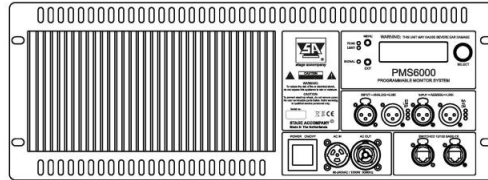

Control panel PMS6000

Champ Series: active/passive loudspeaker systems

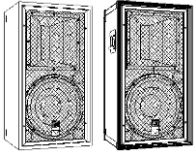

C24 / C24s

- Mid/High cabinet
- 1 x 12"
- 1 x RCD

[C24 TechDoc](#)

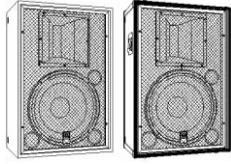

C27 / C27s

- Full-range cabinet
- 1 x 15"
- 1 x RCD

[C27 TechDoc](#)

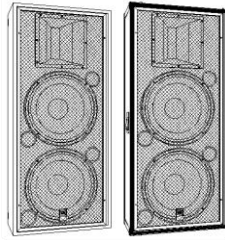

C29 / C29

- Full-range cabinet
- 2 x 15"
- 1 x RCD

[C29 TechDoc](#)

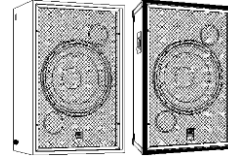

B15 / B15s

- Bass cabinet
- Bass reflex
- 1 x 15"

[B15 TechDoc](#)

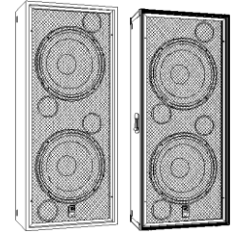

B30 / B30s

- Bass cabinet
- Bass reflex
- 2 x 15"

[B30 TechDoc](#)

Digital Series: digital amplifiers



DS20

- Class-D power amplifier
- 2 x 400W @ 8Ω, 2 x 700W @ 4Ω
- DSP, USB, Ethernet, AES/EBU
- 2HE

[DS20 TechDoc](#)



DS50

- Class-D power amplifier
- 2 x 1600W @ 8Ω, 2 x 2500W @ 4Ω
- DSP, USB, Ethernet, AES/EBU
- DDC
- 2HE

[DS50 TechDoc](#)



HE50

- Class-D power High-End amplifier
- uses No-Compromise audiophile components
- Fan-less design
- 2 x 1600W @ 8Ω, 2 x 2500W @ 4Ω
- DSP, USB, Ethernet, AES/EBU
- DDC
- 3HE

[HE50 TechDoc](#)



SSD420

- Class-D power cinema amplifier
- 4 x 400W @ 8Ω, 4 x 700W @ 4Ω
- DataPort
- 2HE

[SSD420 TechDoc](#)

Direct Screen Series: active/passive cinema loudspeaker system



DS24

- Full-range cabinet
- 1 x 12", Low/Mid
- 1 x RCD, High

[DS24 TechDoc](#)



SSB18

- Bass cabinet
- Bandpass / horn
- 1 x 18"

[SSB18 TechDoc](#)



SSB3

- Bass cabinet
- Bandpass / horn
- 2 x 18"

[SSB18 TechDoc](#)



SSD420

- Class-D power cinema amplifier
- 4 x 400W @ 8Ω, 4 x 700W @ 4Ω
- DataPort
- 2HE

[SSD420 TechDoc](#)

Entertainer Series: passive loudspeaker systems

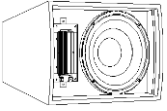

E24

- Full-range cabinet
- 1 x 12"
- 1 x RCD

[E24 TechDoc](#)

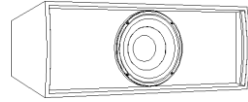

B12

- Bass cabinet
- Bass reflex
- 1 x 12"

[B12 TechDoc](#)

Friend Series: passive fill-in loudspeakers

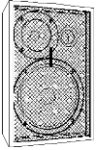

F5

- Full-range cabinet
- 1 x 6.5"
- 1 x 1" soft-dome tweeter

[F5 TechDoc](#)

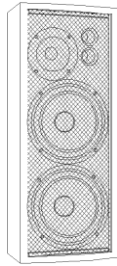

F9

- Full-range cabinet
- 2 x 6.5"
- 1 x 1" soft-dome tweeter

[F9 TechDoc](#)

Genesis Series: active small line array system



GL20b

- Vertical small line array
- 2 x 8"
- 1 x RCD

[GL20b_TechDoc](#)



GL15

- 35-180Hz (+/-3dB)
- 1 x 15" neodymium LF driver

[GL15_TechDoc](#)



GL23

- 65 Hz – 30kHz (+/- 3 db)
- 2 x 6,5" neodymium LF driver
- 1 x RCD

[GL23_TechDoc](#)

Leader Series: active/passive floor monitors

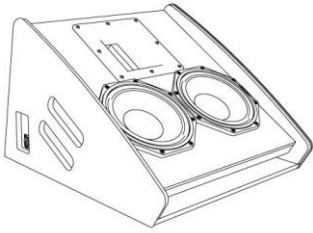

L16

- 65Hz – 30kHz
- 2 x 8"
- 1 x 5"

[L16 TechDoc](#)

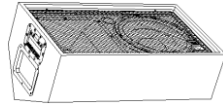

L24

- Floor monitor
- 1 x 12"
- 1 x RCD

[L24 TechDoc](#)

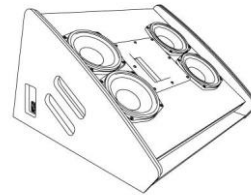

L25

- 62Hz – 30kHz
- 4 x 6,5"
- 1 x 5"

[L25 TechDoc](#)

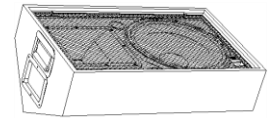

L27

- Floor monitor
- 1 x 15"
- 1 x RCD

[L27 TechDoc](#)

Master Series: active/passive studio monitor systems

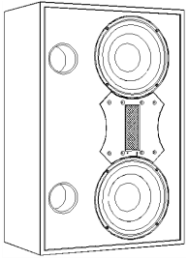

M57

- Studio monitor system
- 2 x 12"
- 1 x RCD

[M57 TechDoc](#)

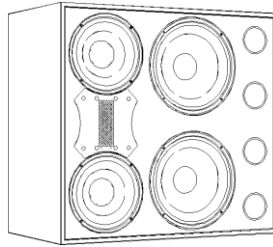

M59

- Studio monitor system
- 2 x 15"
- 2 x 12"
- 1 x RCD

[M59 TechDoc](#)

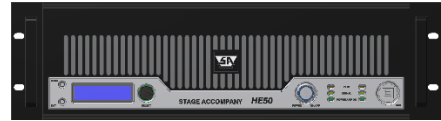

HE50

- Class-D power High-End amplifier
- uses No-Compromise audiophile components
- Fan-less design
- 2 x 1600W @ 8Ω, 2 x 2500W @ 4Ω
- DSP, USB, Ethernet, AES/EBU
- DDC
- 3HE

[HE50 TechDoc](#)

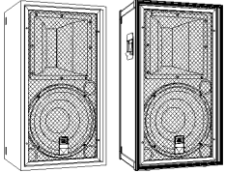

P24 / P24s

- Mid/High cabinet
- 1 x 12"
- 1 x RCD
- Air-system

[P24 TechDoc](#)

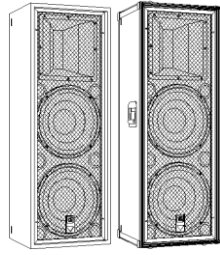

P26 / P26s

- Mid/High cabinet
- 2 x 12"
- 1 x RCD
- Air-system

[P26 TechDoc](#)

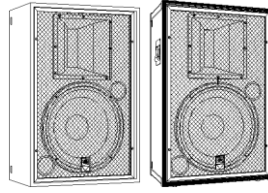

P27 / P27s

- Mid/High cabinet
- 1 x 15"
- 1 x RCD
- Air-system

[P27 TechDoc](#)

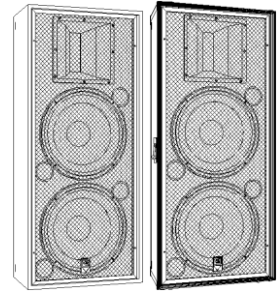

P29 / P29s

- Mid/High cabinet
- 2 x 15"
- 1 x RCD
- Air-system

[P29 TechDoc](#)

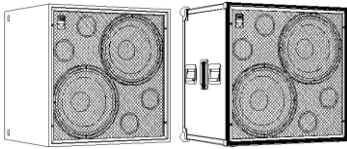

P16 / P16s

- Bass cabinet
- Bass reflex
- 2 x 15"

[P16 TechDoc](#)

Prompter Series: passive loudspeaker systems



PR34

- Full-range cabinet, multifunctional
- 1 x 12"
- 1 x RCD

[PR34 TechDoc](#)

Screen Series: slim line cinema loudspeaker systems



S26

- Full-range front system
- 2 x 12"
- 1 x RCD

[S26 TechDoc](#)

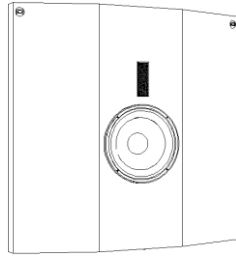

S27

- Full-range front system
- 1 x 15"
- 1 x RCD

[S27 TechDoc](#)

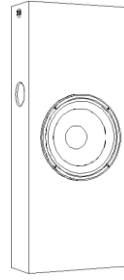

SL15

- Slim line bass cabinet
- Bass reflex
- 1 x 15"

[SL15 TechDoc](#)

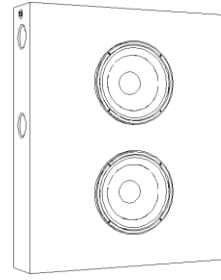

SL30

- Slim line bass cabinet
- Bass reflex
- 2 x 15"

[SL30 TechDoc](#)

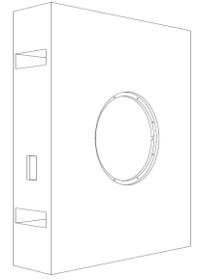

SL18

- Slim line bass cabinet
- Bass Reflex
- 1 x 18"

[SL18 TechDoc](#)



S5

- Full-range wedged surround cabinet
- 1 x 6.5"
- 1 x 1" soft-dome tweeter

[S5 TechDoc](#)

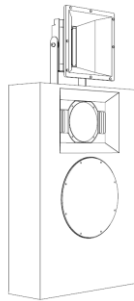

S31

- Full-range front system
- 1 x 12"
- 1 x 6"
- 1 x RCD

[S31 TechDoc](#)



SSD420

- Class-D power cinema amplifier
- 4 x 400W @ 8Ω, 4 x 700W @ 4Ω
- DataPort
- 2HE

[SSD420 TechDoc](#)



S10

- 56Hz – 40kHz
- 1 x 10"
- 1 x 5"

[S10 TechDoc](#)

S14

- 56Hz – 40kHz
- 1 x 10"
- 1 x 5"

[S14 TechDoc](#)



Stage Accompany bv
Haven 28
2984 BR Ridderkerk
The Netherlands
Tel; 31 (0)180 426225
Fax: 31 (0)180 421831
E-mail: info@StageAccompany.com

Copyright 2013 Stage Accompany bv.
The information in this document is continuously being developed. Whilst every effort has been made to make it as accurate as possible, no warranty of accuracy is made or implied by the makers. Stage accompany shall have neither liability, nor responsibility to any person or entity with the respect to loss or damages in connection with or arising from the information contained in this document

That's How Music Should Sound