

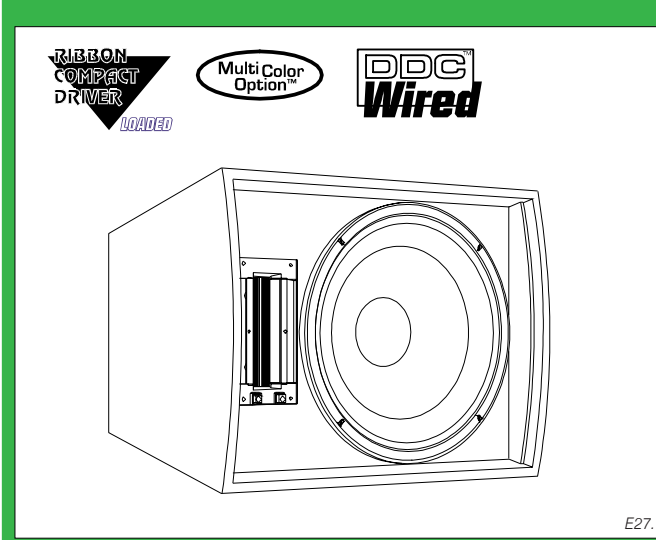

stage accompany

Technical specifications E27



Entertainer E27

In this documentation you will find information about:

- Description
- Placement
- Maintenance
- Connection
- Options
- Dynamic Damping Control™
- Recommendations
- Technical specifications

Description

The E27 is a full-range cabinet, with single SA 1513 long excursion 15" woofer in combination with an SA 8535 Ribbon Compact Driver, recommended for applications where medium output, high quality reinforcement is needed.

Placement

Mounting of the E27 can be done in three ways. You can fly the E27 by using the small Uni-Rig™ flying points. You can mount it with the FRK-bracket or with an Omnimount™. If you use the small flying system there must be a space of minimal 7 cm (2.7 in.) between the E27 and the wall.

(for dimensions, see back). If you don't want to use the mounting options then fill the unused holes in the E27 with the plastic caps.

Maintenance

Maintenance on the E27, especially on the drivers and filters is best left to official Stage Accompany service personnel.

Connection

The E27 has two 4-pole Speakon connectors and one spring terminal connector. Connecting can be done in two ways; with a 4-pole speakon or with the spring terminal connector (for use with loose wires). When using Speakon connectors, be sure that you use the 'Input' socket (see connectorpanel). In case you want to link several E27 cabinets to the same channel, then it is easy to link them by using the 'Link' socket.

(Caution: When linking, make sure nominal impedance stays within amplifier specification!). If you are using loose wires then be aware of the right polarity.

Options

The E27 is standard finished in SA Black Protecture, but is also available in any possible RAL color (Multi Color Option™). Small Uni-Rig fly-points (3)

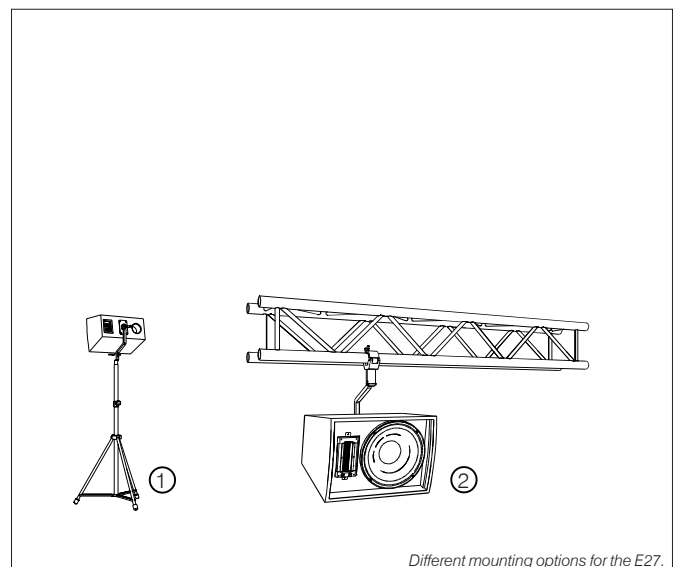
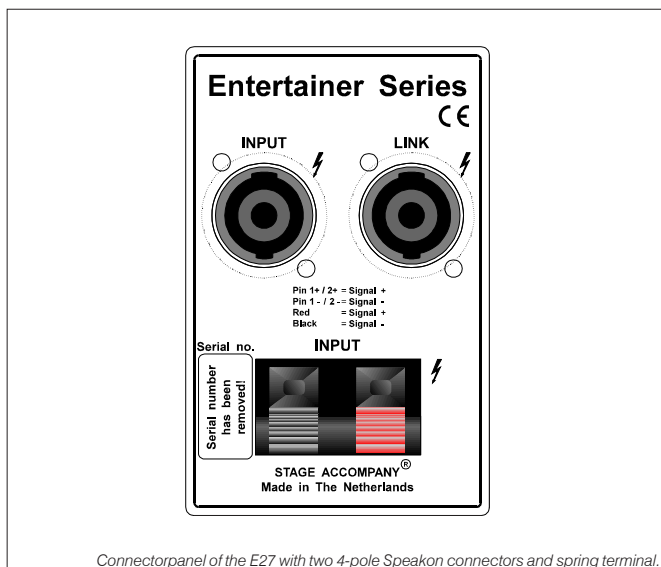

Dynamic Damping Control (DDC™)

For absolute top quality sound reproduction, the E27 is completely pre wired for Dynamic Damping Control™.

The DDC™ system is based on 2 loudspeaker wires that return from the speaker to the (SA) amplifier. Through these "sense wires" the amplifier can compensate the speaker cable and connector resistance, ensuring maximum control over the speaker cone movement.

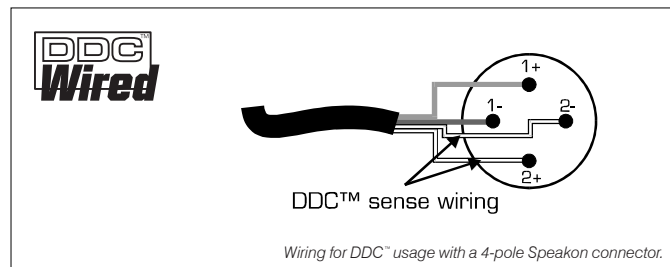

Recommendations

To use the E27 we recommend the ES Series power amplifier. This amplifier is standard equipped with DDC™, resulting in a virtually infinite amplifier damping factor at the speaker terminals. To use the DDC™ system with an Efficiency Series amplifier, use Stage Accompany 4-pole LW Speakon cable. The Extended Function Network (EFN™) module can provide dedicated filtering and protection within the amplifier.

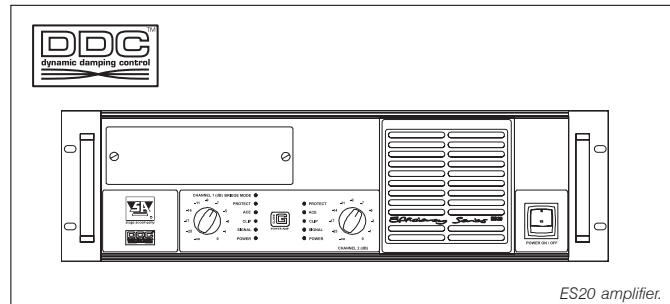

Technical specifications

Frequency response	: 52 Hz - 30 kHz (+/- 3dB)
Drivers	: 1 x SA 1513 LF driver; 1 x SA 8535 MF/HF driver
Cross-over frequentie	: 1300 Hz
Nominal impedance	: 8 Ohm
Sensitivity @ 1W/1m	: 96 dB
Max. RMS power	: 400 W
Max. Peak power	: 1000 W
SPL program/peak (dB)	: 122/126
Dispersion (2 kHz H x V)	: 90° x 70°
Color	: SA Black, other colors on request
Front	: Expanded metal grille + acoustic transparent cloth
Connectors	: 2 x 4-pole Speakon; 1 x Input, 1 x Link, 1 x Terminal
Physical dimensions (h x w x d)	: 437 x 578 x 342 mm (17.2 x 23.9 x 13.5 in.)
Weight	: 27.5 kg (60.7 lb)

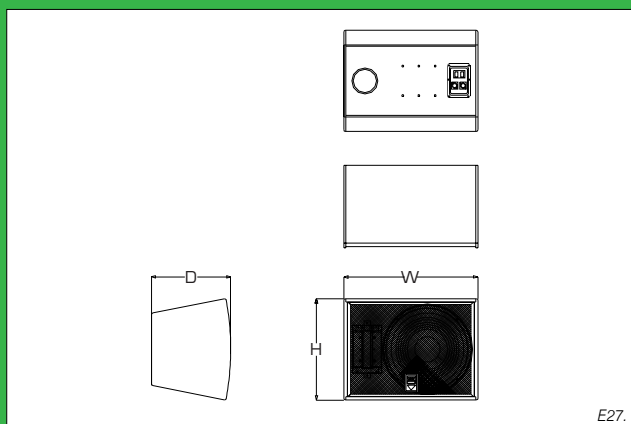

Stage Accompany
Anodeweg 4
1627 LJ HOORN
The Netherlands
Tel: +31 (0)229 282930
Fax: +31 (0)229 282920
E-mail: info@StageAccompany.com

© Copyright 2000-2005 Stage Accompany.

The information in this document is continually being developed. Whilst every effort has been made to make it as accurate as possible, no warranty of accuracy is made or implied by the makers. Stage Accompany shall have neither liability, nor responsibility to any person or entity with respect to loss or damages in connection with or arising from the information contained in this document.

www.StageAccompany.com

That's How Music Should Sound!