

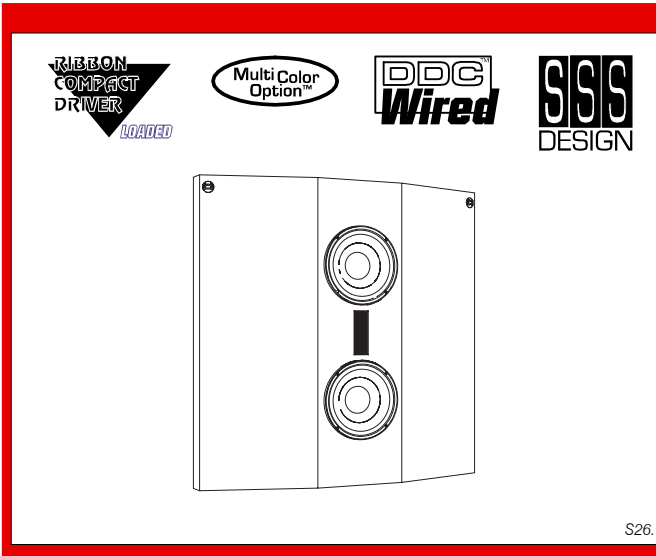

stage accompany

Technical specifications S26



Screen S26

In this documentation you will find information about:

- Description
- Placement
- Active/passive version
- Connection
- Options
- Mounting System
- Dynamic Damping Control™
- Recommendations

Description

The S26 is a full-range cinema front system, with double SA 1203 soft-suspension 12" speakers with 4-in. voice-coils, in combination with an SA 8535 Ribbon Compact Driver, mounted in an ultra-slim sized MDF/birch cabinet. The S26 is recommended for applications where high output, high quality cinema sound reinforcement is needed.

Note: Due to the placement of the components in the cabinet, the S26 system is completely time-aligned and does not need any delay/correction.

Placement

The Super Space Saving design enables the S26 to be flown behind the screen with a minimum of space required. Mounting is done by attaching cable or chain to two shoulder eyebolts, which are located on the front of the cabinet. Placing the S26 on a platform is not possible because of the bass reflex vents, which are located on the top and bottom of the cabinet.

Active/passive version

The S26 is available with active (bi-amp) or passive (single-amp) filtering. Please specify when ordering.

Connection

The S26 passive version uses one 4-pole Speakon connector ("input"), the active version uses two 4-pole Speakon connectors ("low", "high"). Caution!; Incorrect connection with a S26 in bi-amp version can cause damage to the loudspeaker components!

Options

The S26 is standard finished in SA Black Protecture™ and is also available in any possible RAL color through "Multi Color Option™".

Mounting system

Mounting is done by attaching steel cable or chain to the two shoulder eyebolts, which are located on the front of the cabinet. The steel cables or chains can be lowered from the screen frame or ceiling. When mounting the cabinet in a very tight space, utilizing a pulley-hoist makes mounting easy. A third flying point is located on the lower back side of the cabinet, to enable tilting of the cabinet when necessary. Caution! Before mounting, make sure the construction stays within working load limits! For optimum performance, it is recommended to mount the S26 as close to the screen as possible (screen distance 2.5cm/1-in).

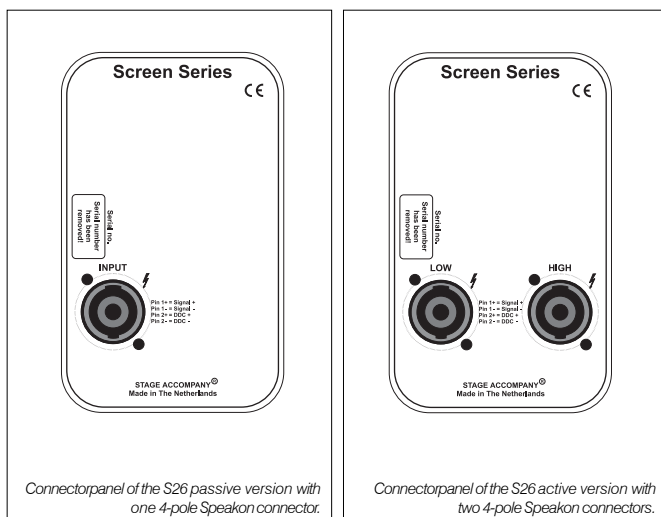

Connectorpanel of the S26 passive version with one 4-pole Speakon connector.

Connectorpanel of the S26 active version with two 4-pole Speakon connectors.

Dynamic Damping Control

For absolute top quality sound reproduction, the S26 is completely pre-wired for Dynamic Damping Control™. The DDC™ system is based on two additional (loudspeaker) wires between speaker and the (SA) amplifier. Through these "sense" wires, the DDC™ circuitry in the amplifier compensates speaker cable and connector resistance, ensuring maximum control over the speaker cone movement.

Furthermore, with DDC™, distortion is reduced substantially.

Recommendation

To use the S26 we recommend the SSA200 power amplifier. This amplifier is standard equipped with DDC™, resulting in a virtually infinite damping factor at the speaker terminals. To use the DDC™ system with a SSA200 amplifier, use 4-core speaker cable. The SSA200's Extended Function Network ("EFN™") provides dedicated filtering, power optimizing and protection for the S26 (EFN-DP).

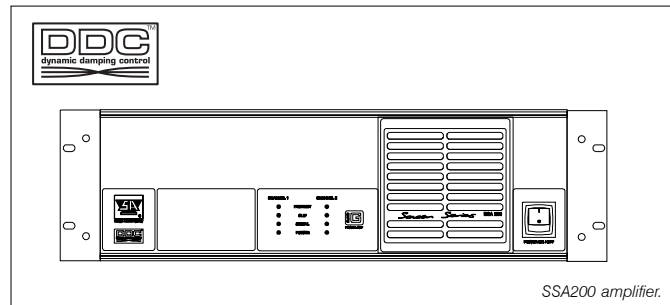
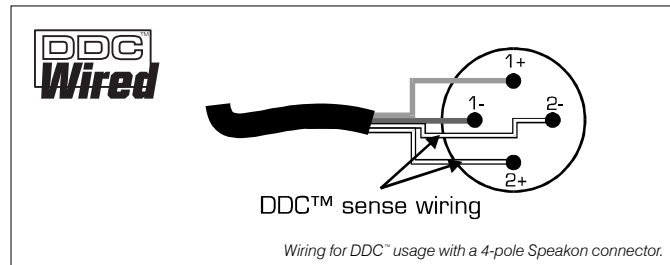

Technical specifications

Passive version

Active version

Frequency response	: 35 Hz - 30 kHz (+/- 3dB)	
Drivers	: 2 x SA 1203 LF driver, 1 x SA 8535 HF driver	
Cross-over frequency	: 1400 Hz	
Nominal impedance	: 4 Ohm	4 Ohm (LF), 13 Ohm (HF)
Sensitivity @ 1W/1m	: 97 dB	97 dB (LF), 103 dB (HF)
Max. RMS power	: 800 W	800 W (LF), 60 W (HF)
Max. Peak power	: 2000 W	2000 W (LF), 1000 W (HF)
SPL program/peak (dB)	: 126/130	126/130 (LF), 121/133 W (HF)
Dispersion (2 kHz H x V)	: 100° x 40°	
Color	: SA Black, other colors on request	
Connectors	: 1 x 4 pole Speakon input	2 x 4 pole Speakon input; 1 x LF, 1 x HF
Physical dimensions (h x w x d)	: 1200 x 1200 x 230 mm (47.2 x 47.2 x 9.1 in.)	
Weight	: 73.8 kg (162.7 lb)	
Warranty:	: 5 years limited (1 year on "moving parts")	

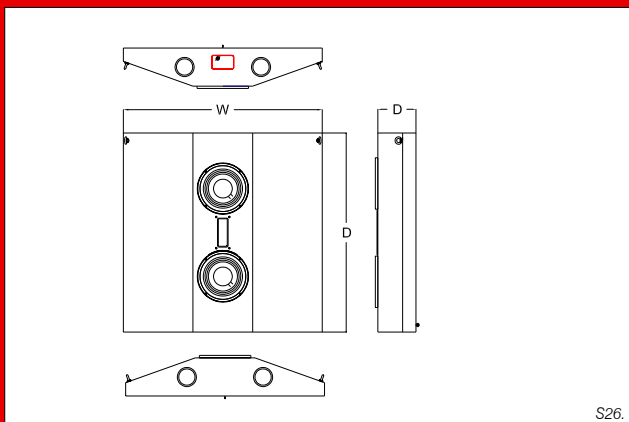

Stage Accompany
Anodeweg 4
1627 LJ HOORN
The Netherlands
Tel: +31 (0)229 282930
Fax: +31 (0)229 282920
E-mail: info@StageAccompany.com

© Copyright 2001-2005 Stage Accompany.

The information in this document is continually being developed. Whilst every effort has been made to make it as accurate as possible, no warranty of accuracy is made or implied by the makers. Stage Accompany shall have neither liability, nor responsibility to any person or entity with respect to loss or damages in connection with or arising from the information contained in this document.

www.StageAccompany.com

That's How Music Should Sound!